

# CBCS SCHEME

USN

--	--	--	--	--	--	--	--	--	--

17AU53

## Fifth Semester B.E. Degree Examination, Jan./Feb. 2023 Design of Machine Elements - I

Time: 3 hrs.

Max. Marks: 100

Note: Answer any FIVE full questions, choosing ONE full question from each module.

### Module-1

- 1 a. Define the following mechanical properties:  
(i) Stiffness (ii) Ductility (iii) Toughness (iv) Resilience (v) Creep (10 Marks)
- b. A hydraulic press exerts a total load of 3.5 MN. This load is carried by two steel rods, supporting the upper head of the press. If the safe stress is 85 MPa and  $E = 210 \text{ kN/mm}^2$ . Find: (i) Diameter of the rods (ii) Extension in each rod in a length of 2.5 m (10 Marks)

OR

- 2 a. Explain: (i) Maximum principal stress theory (ii) Maximum shear stress theory (10 Marks)
- b. A cylindrical shaft made of steel of yield strength 700 MPa is subjected to static loads consisting of bending moment 10 kN-m and a torsional moment 30 kN-m. Determine the diameter of the shaft using maximum shear stress theory. Take factor of safety 2 and  $E = 210 \text{ GPa}$ , Poisson's ratio = 0.25. (10 Marks)

### Module-2

- 3 a. With neat sketch, explain the methods of reducing stress concentration. (10 Marks)
- b. Find the maximum stress induced in the following cases taking stress concentration into account.

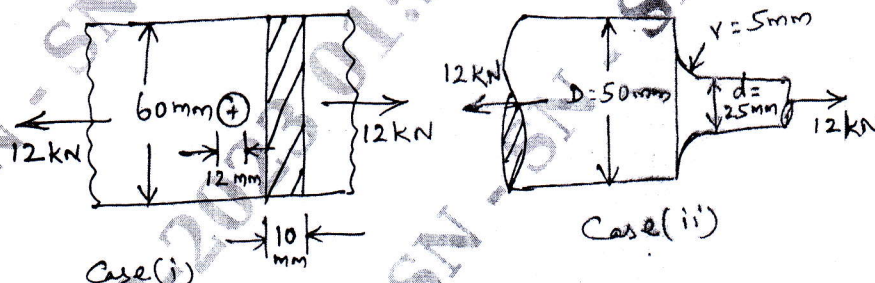

Fig.Q3(b)

(10 Marks)

OR

- 4 a. Write short notes on Notch Sensitivity. (10 Marks)
- b. Determine the thickness of a 120 mm wide uniform plate for safe continuous operation if the plate is to be subjected to a tensile load that has a maximum value of 250 kN and a minimum value of 100 kN. The properties of the plate material are as follows:  
Endurance limit stress = 225 MPa  
Yield point stress = 300 MPa  
Factor of safety = 1.5 (10 Marks)

### Module-3

- 5 Design a knuckle joint to transmit 150 kN. The design stresses may be taken as 70 MPa in tension, 60 MPa in shear and 150 MPa in compression. (20 Marks)

Important Note : 1. On completing your answers, compulsorily draw diagonal cross lines on the remaining blank pages.  
2. Any revealing of identification, appeal to evaluator and/or equations written eg, 42+8 = 50, will be treated as malpractice.

OR

- 6 a. A shaft made of mild steel is required to transmit 100 kW at 300 rpm. The supported length of the shaft is 3m. It carries two pulleys each weighing 1500 N supported at a distance of 1 m from the ends respectively. Take the safe value of stress  $\tau = 60 \text{ N/mm}^2$ . Determine the diameter of the shaft. (10 Marks)
- b. Explain the types of shafts and write the properties required for shaft material. (10 Marks)

Module-4

- 7 a. Define the following terms used in riveted joints:  
 (i) Pitch (ii) Back pitch (iii) Diagonal pitch  
 (iv) Margin (v) Caulking (10 Marks)
- b. Find the efficiency of single riveted lap joint of 6 mm plates with 20 mm diameter rivets having a pitch of 50 mm. (10 Marks)

OR

- 8 a. A welded joint as shown in Fig.Q8(a) is subjected to an eccentric load of 2 kN. Find the size of weld, if the maximum shear stress in the weld is 25 MPa.

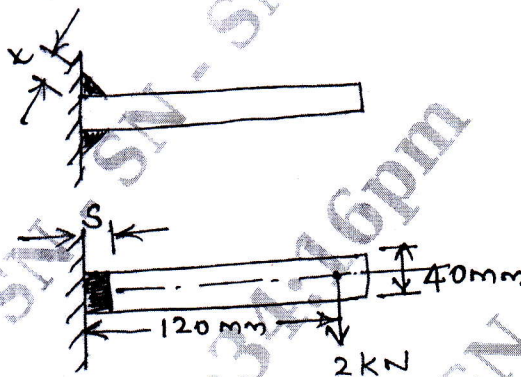

Fig.Q8(a)

- b. With neat sketches, explain the types of welded joints. (10 Marks)

Module-5

- 9 a. A lever loaded safety valve has a diameter of 100 mm and the blow off pressure is  $1.6 \text{ N/mm}^2$ . The fulcrum of the lever is screwed into the cast iron body of the cover. Find the diameter of the threaded part of the fulcrum if the permissible tensile stress is limited to 50 MPa and the leverage ratio is 8. (10 Marks)
- b. Sketch and label a screw thread and define all the terms used in screw threads. (10 Marks)

OR

- 10 A screw jack is to lift a load of 80 kN through a height of 400 mm. The elastic strength of screw material in tension and compression is 200 MPa and in shear 120 MPa. The material for nut is phosphor bronze for which the elastic limit may be taken as 100 MPa in tension, 90 MPa in compression, and 80 MPa in shear. The bearing pressure between the nut and the screw is not to exceed  $18 \text{ N/mm}^2$ . Design the screw jack. Take factor of safety  $n = 2$ . (20 Marks)

\*\*\*\*\*